

- NOTES:**
- 1.) Post size depends on fence height and wind loads. See MONTAGE II™ specifications for post sizing chart and setting dimensions.
 - 2.) Third & Forth rail optional.
 - 3.) Available in Flush Bottom.

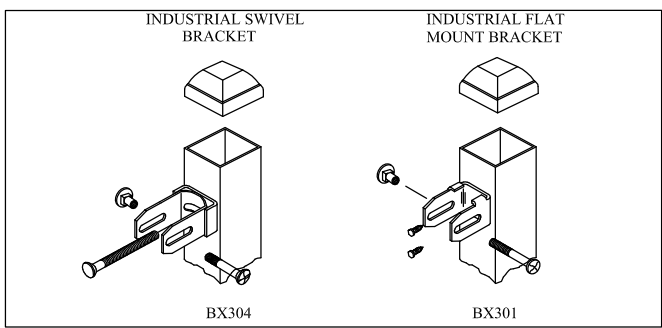
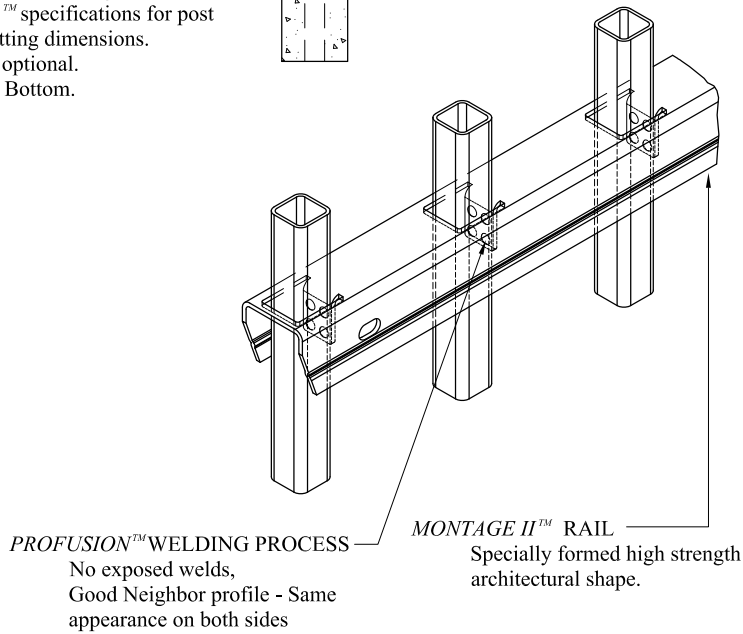
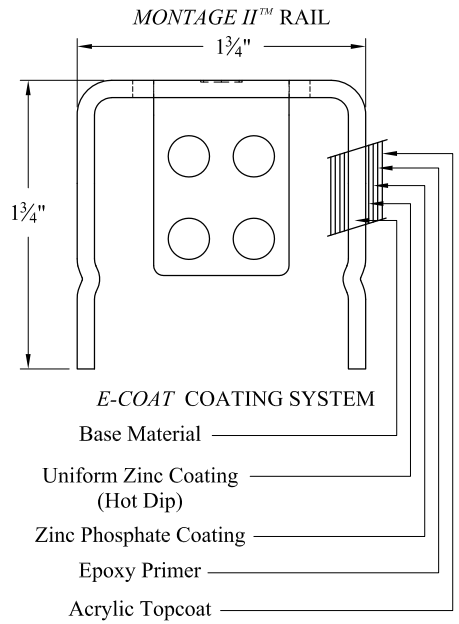

Values shown are nominal and not to be used for installation purposes. See product specification for installation requirements.

HEAVY INDUSTRIAL STRENGTH WELDED STEEL PANEL
PRE-ASSEMBLED

Title: MONTAGE II INVINCIBLE 2/3/4-RAIL			
DR: CI	SH . 1 of 1	SCALE: DO NOT SCALE	
CK: PB	Date 6/28/10	REV: c	

Ameristar Montage II Invincible Fence
Distributed by:
Ornamental Fence Supply, LLC
Big Rock, IL Phone: 800-448-1293 www.ornamentalfencesupply.com